

4. Solar Energy I

All the energy strategies include solar energy as a major option for middle term and long term development. Although the solar energy is considered unconventional yet, owing to some advantages its participation to the energy consumption increases rapidly. Thus, solar energy is:

- renewable,
- almost uniformly distributed on the earth populated surface,
- costless,
- utilizable with very small environmental effect.

Some of solar energy drawbacks are:

- small surface density
- daily and yearly variations because of earth motions,
- strong influence of the atmosphere nebulousness and pollution.

There are two main ways of access to the solar radiation: thermal conversion and direct conversion into electricity. Although the thermal conversion is now more spread, the direct electrical conversion appears to be the most important for long term programs.

Solar radiation

The sun is a complex structure with many concentric zones, whose temperature increases from surface to centre. As an energy source, the main characteristics of the sun are:

- surface medium temperature 5762 K,
- angular amplitude from the earth 32' (0.01 radian),
- sun to earth average distance $1.5 \cdot 10^8$ km.

The solar radiation has two main characteristics: the **solar constant** and the **spectral distribution**.

The average energy radiated by the sun in the time unit on an unitary surface set outside the atmosphere and pointed perpendicularly to the sun rays, is known as **the solar constant**; its value is $1\,367 \text{ W/m}^2$ ($1,96 \text{ cal/cm}^2\text{min}$) according to the most recent estimate.

During the annual revolution movement of the earth, the sun-earth distance changes and so does the solar constant: approximately between 1322 W/m^2 (at summer solstice in the North Hemisphere) and 1415 W/m^2 (at autumnal equinox). Another change of the solar constant is owed to the solar activity that has a cycle of 9-11 years. This change is only of 2-3%.

The spectral distribution of solar radiation is represented by radiation intensity I ($\text{W/m}^2 \cdot \mu\text{m}$), according to fig. 2. The solid line corresponds for the extra atmospheric radiation and the dotted one for the sea level on earth. The maximum radiation

intensity appears in the visible wave length domain, for the blue color.

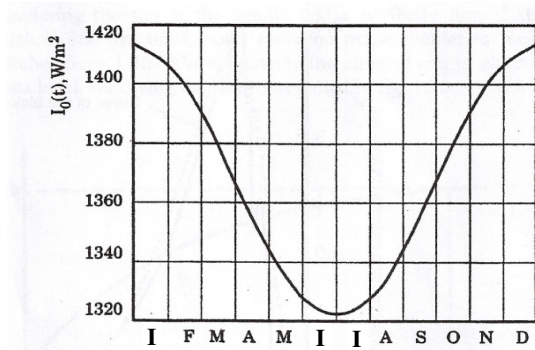

Fig. 1 Variation of extraterrestrial radiation during the year

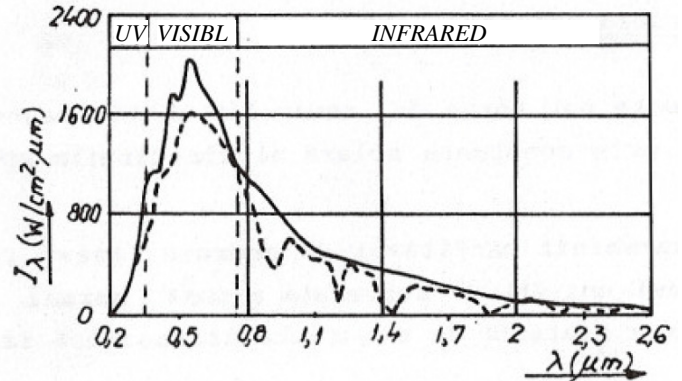

Fig. 2 Spectral distribution of the solar constant

The area between the spectral distribution curve and the axis system represents, numerically, the solar constant:

$$E = \int_0^{\infty} I_{\lambda}(\lambda) d\lambda \quad (1)$$

where λ is the wave-length.

Table 1 shows the partition of the solar radiation energy between the main domains of wave-length.

Table 1. Spectral composition of the extra atmospheric solar radiation energy

Domain	Wave length (μm)	Domain weight (%)	Cumulated weight (%)
Ultraviolet	0.015 - 0.38	6.15	6.15
Visible	0.38 - 0.80	49.87	56.02
Infrared 1	0.80 - 5.0	43.49	99.51
Infrared 2	5.0 - 400	0.49	100.00

By crossing the earth atmosphere, the solar radiation is subjected to many phenomena such as reflexion, absorption and diffusion, as follows:

- a part of radiation is absorbed in a selective mode and radiated again, but in all directions, and so with an effective loss of intensity;
- a part of radiation is spread in all directions in the impact with the gas molecules and with the particle of dust present in the atmosphere. The impact with the gas molecules (Raleygh scattering) causes a spread proportional to λ^{-4} (this explains the blue color of the sky) while the impact with the dust creates a spreading proportional with λ^{-1} .
- a part of solar radiation is reflected toward the space by the clouds;
- the remaining part reaches the earth surface directly and constitutes the direct radiation.

The evaluation of solar radiation parameters at earth surface can be achieved by some methods: analytical, direct measuring and correlation functions.

The analytical method consists in mathematical modeling of physical processes described above, which act along the path of the radiation through atmosphere.

Considering the atmosphere as homogeneous, the solar radiation attenuation depends on the distance to the earth surface

$$I_{\lambda} = I_{0\lambda} e^{-c_{\lambda} m} \quad (2)$$

and the wave length λ . The distance influence is introduced by the parameter m - the relative air mass, whose definition is: m is the ratio between the masses of two air columns - one ranged along the solar beam; the other ranged vertically (fig.3).

The relative air mass m at sea level can be calculated with the approximated formula

$$m = \frac{1}{\sin \alpha} \quad (3)$$

To use the analytical method, many parameters of the atmosphere must be known. Because these parameters changes

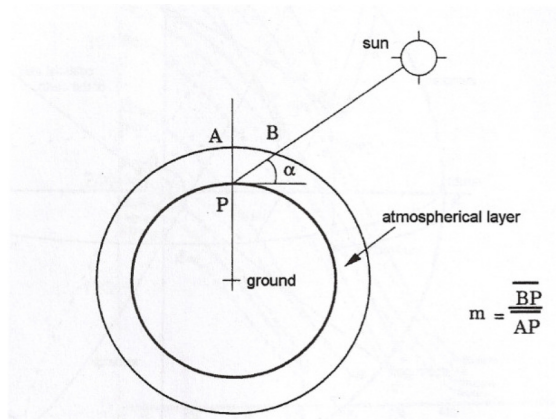

Fig 13 Definition of the relative air mass.

frequently, this method can be used only as reference.

Considering the sun at the zenith, and a perfect limpid atmosphere which is 100 km thick, the solar radiation density switches from 1367 W/m² to about 1000 W/m² at sea level.

The direct measuring can be performed using devices based either on the photoelectric effect or the thermal conversion of the radiation.

Correlation functions were established using the registered values of the solar constant and of the atmospheric parameters like, pressure, temperature, wind velocity, daily or annual hours of sun shining.

Photoelectric conversion of solar radiation

The direct conversion of the solar energy into electricity without passing through thermal processes is made possible by

using the photovoltaic effect, through which an electromotive force is produced as result of the absorption of the solar radiation by some devices called **solar cells**.

There are two photovoltaic effects:

- the external effect which consists in extracting electrons from irradiated metal surface;
- the internal effect, which consists in generating free charge carriers (electrons and holes) in semiconductor materials.

For energy conversion, only the internal photoelectric effect is important.

To understand, at least from a qualitative point of view, the way the photovoltaic conversion of radiation occurs, consider the crystalline lattice of silicon (fig.4), in which each atom is surrounded by other four and in which each of them shares one of its four valence electrons, belonging to the more external orbits. In this way, it has the possibility to complete the external octet and make the configuration stable.

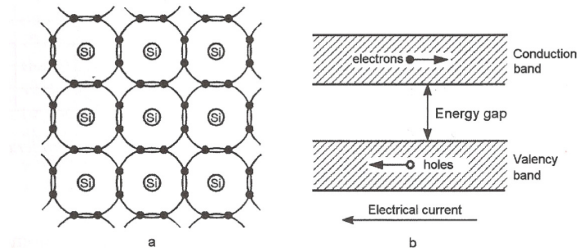

Fig. 4 - Representation of the crystal lattice of silicon and the valency and conduction bands.

The electrons belonging to the more internal orbits are strongly linked to the core instead and so are not involved in the relations with the other atoms and in electrical conduction.

In a crystal of this kind, called intrinsic, all the electrons, connected to the other atoms in covalent links, belong to the valence band of energy and, unless external factor occurs, they do not have sufficient power to switch to the conduction band.

The existence of valence and conduction bands comes from the "exclusion principle" of Pauli, which stated each electron in an isolated atom occupies a different level from all the others and corresponding to a definite quantum state. However, in a lattice, the effect of proximity of a large number of equal atoms makes the structure change from levels to power bands, which makes each electron able to occupy any power level inside each band.

The electrons in the conduction band - as they are free to move in the lattice (at least until their recombination)- can operate as load carriers in an electrical current, as occurs in the case of conductor materials, in which the more external electrons of each atom already belong to the conduction band, that is partially overlaid to the valence one. Vice versa, in

insulating materials, where the two bands are very different concerning the energy, it is very difficult to the conduction band to be populated with electrons and for the electrical current to be present.

In semiconductor materials, the valence and the conduction bands, as can be seen in figure 4, are separated between them by a power gap of value E_g much lower the one specific for an insulating material. Providing an electron with this gap power (from a photon), the electron can jump from the lower to the upper band.

Not all the photons can promote an electron from the valence band to the conduction one, but only those having a power content higher or equal to the power gap. The power of a photon is

$$\varepsilon = h\nu \quad (4)$$

where $h = 6.625 \cdot 10^{-34}$ Js is the constant of Planck, and ν (s^{-1}) is the frequency of the radiation, connected to the wave-length by the equation

$$\nu = \frac{c}{\lambda} \quad (5)$$

where $c = 3 \cdot 10^8$ m/s is the light speed. Combining the previous two equation you find:

$$\varepsilon = \frac{hc}{\lambda} \quad (6)$$

which shows that the photons with shorter wave-length are more powerful.

In the case of silicon (Si) which has a gap power equal to $1.12 \text{ eV} = 1.12 \times 1,6 \cdot 10^{-19} \text{ J}$, we can find a maximum wave-length at which the solar radiation produces the photoelectric effect. This value is equal to:

$$\lambda_{\max} = \frac{hc}{E_g} = \frac{6.625 \cdot 10^{-34} \times 3 \cdot 10^8}{1,12 \times 1,6 \cdot 10^{-19}} = 1,11 \cdot 10^{-6} \text{ m}$$

The radiation with wave-length higher than $1.11 \mu\text{m}$ (equal to about the 25% of the solar power contained in the spectrum) cannot produce electrical power in the silicon cells.

In semiconductor materials, as silicon, each electron switching to the conduction band frees a place in the valence band, called "hole", which can move under the effect of an electrical field, too, as it behaves like a positive load carrier. So, in the grid of a crystal made with semiconductor material, the electrical conduction can occur after the motion of the electrons in the conduction band and the holes in the valence band.

Inside the crystal lattice, if an atom is that has 3 electrons in the more external orbit is installed (e.g. an atom of boron, B), a hole creates in the valence band (fig.5,a). Instead, if that atom has 5 external electrons (e.g. Phosphorous, P), the

resulting effect will be to have 1 more electron (fig.5,b). In the first case the inserted atom is called acceptor and the semiconductor becomes type P, while in the second case it is a donor and the semiconductor becomes type N.

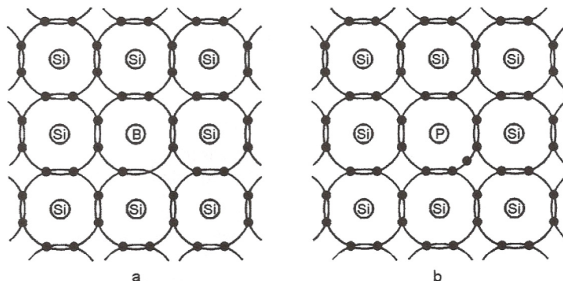

Figure 5 — Diagram of the crystal lattice of silicon type P and N.

The insertion of other atoms in the semiconductor lattice is called **doping** and must not be carried out over a certain proportion in order to not interfere too much with the crystal geometry. In fact, an average doping expects the insertion of about 10^{15} atoms of doping element per cm^3 in the silicon lattice, which totally contains $5 \cdot 10^{23}$ atoms. For comparison, consider that, at ambient temperature, the concentration of electrons in the conduction band of the intrinsic silicon, i.e. not doped, is in the order of 10^{10} electrons/ cm^3 , so the doping atoms determine the actual conductivity of the semiconductor.

The basic solar cell is a junction of two different type semiconductors: *p* and *n*. If both zones differ only by the conduction mode but are build from the same material the cell is called homojunction. But, if both the conduction type and the material are different, the cell is a heterojunction. Besides these, other two types of solar cell were developed: the metal-semiconductor cell and the metal-electrolyte cell.

The photoelectric effect in the homojunction p-n.

If two silicon crystal, type P and type N, are set in touch, a P-N junction is obtained. By diffusion, the holes present in the region P will tend to diffuse to the region N, while free electrons present in the region N will tend to move to the P one. However, this movement continues until the electrical potential generated by the load shift is high enough to counterbalance the diffusion motion.

As can be seen in fig.6, in equilibrium condition, the junction P-N is characterized by a border region, called spatial or depletion load, in which there is the load exchange between the differently doped portions of crystal and by an electrical potential increasing from N to P.

The junction schematized in the fig. 6 is employed in electronics to create a semiconductor diode, but at the same time it constitutes a solar cell, too.

In the case of a diode, applying o voltage between P an N (the negative on the side P and the positive on the side N), the

inner electrical potential adds to the external one not permitting the passage of loads (except for a weak saturation current I_0 due to the creation of electron/hole pairs from the thermal effect).

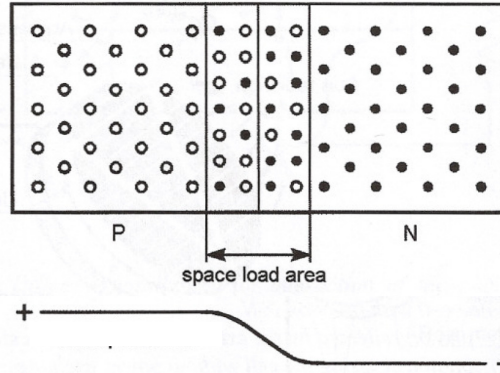

Fig.6 — Diagram of the junction P-N.

On the contrary, if the external voltage is in direct sense applied, the external field will stimulate the motion of the free loads, so the current through the device becomes the diode current:

$$I_d = I_0 \left(e^{qU/kT} - 1 \right), \quad (7)$$

where

I_0 is the inverse saturation current,
 U is the applied voltage,
 q is the electron charge,
 k is the Boltzman constant
 T is the temperature ($^{\circ}\text{K}$).

Now, considering the junction without the external source but exposed to the sun, the photons penetrate the cell. When a photon having more energy than the semiconductor power gap, transfers the energy to a valence electron, that electron becomes free. That electron frees a place in the valence layer of the atom, called *hole*.

The pairs of load generated in this way undergo the influence of the inner electrical field at the junction and move consequently: the electrons generated in the region P are directed to the region N, while the holes generated in the region N are attracted toward the region P.

Because of these load carriers accumulations, a voltage U appears between the two regions, lowering the potential barrier height like when the no illuminated cell is directly polarized. The photovoltaic cell behaves as a generator with the positive pole on the layer P and the negative one on the layer N. As consequence, two currents flow through the junction in opposite sense: the diode current I_d and the light current I_L . The cell total current is:

$$I = I_0 \left(e^{qU/kT} - 1 \right) - I_L. \quad (8)$$

In the ideal case, the photoelectric voltage U would be equal to the potential barrier height E . Actually, always $U < E$, at the most $U = 2/3 E$. The equation (8) shows that the curve $U-I$ for the solar cell is shifted below the curve for the diode with a distance equal to I_L (fig.7). Thus, the solar cell curve is located in the fourth quadrant, where $P=UI < 0$, what, according to

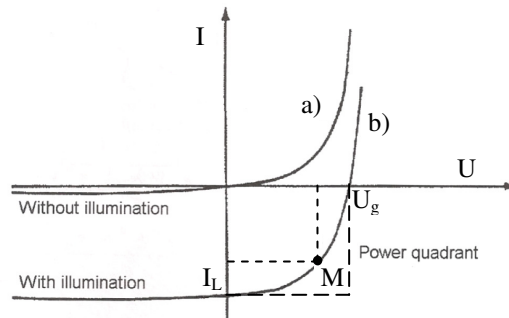

Fig. 7 - Current-voltage characteristic of the junction P-N: a) not illuminated; b) illuminated.

the 2nd law of thermodynamics, is the case of a energy source.

An equivalent circuit for a solar cell can be drawn according the above relation (fig.8). This circuit is composed of a constant current source, a direct polarized diode, the internal impedance R_S and the consumer R_C .

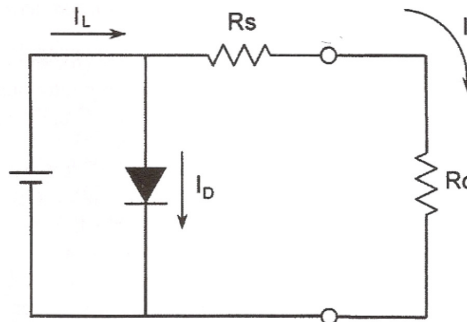

Fig. 8 - Equivalent electrical circuit of a photovoltaic cell.

Solar cell parameters

a) *Short circuit current*: if the cell terminals are connected through a zero impedance conductor, the voltage drops to zero, and the current will be:

$$I = - I_L \quad (9)$$

Thus, the short circuit current is equal to the light current what depends on the number of free charge carriers generated by the absorbed photons and directed by the internal electric field

of the cell. This number can be written as a part γ from N , the entire number of the photons reaching the cell surface:

$$I_L = \gamma e N . \quad (10)$$

As a consequence, the short circuit current intensity is direct proportional with the light intensity.

b) *No load voltage*. When no consumer is connected to the cell terminals, the current intensity is zero and the voltage has the maximum size, U_g .

$$U_g = \frac{kT}{q} \ln \left(\frac{I_L}{I_0} + 1 \right) \quad (11)$$

This equation shows that the no load voltage follows the radiation intensity upon a logarithmic law.

c) The *generated power* is

$$P = |UI| = U \left[I_L - I_0 \left(e^{qU/kT} - 1 \right) \right] \quad (12)$$

representing the area of the rectangle defined in fig. 7. This area depends on the impedance \mathbf{R} connected to the cell terminals, reaching its maximum for the operating point \mathbf{M} . The co-ordinates U_M , I_M corresponding to the point \mathbf{M} can be obtained from the equation

$$\frac{dP}{dU} = 0 . \quad (13)$$

The results are:

$$U_M = U_g - \frac{kT}{q} \ln \left(1 + \frac{qU_M}{kT} \right) \quad (14)$$

and

$$I_M = (I_L + I_0) \frac{qU_M}{kT + qU_M} . \quad (15)$$

Thus, the peak power delivered by the cell will be

$$P_M = (I_L + I_0) \frac{qU_M^2}{kT + qU_M} \quad (16)$$

d) The cell *fill factor* is defined as the ratio of the two surface area noted by dotted lines in fig. 7

$$f = \frac{U_M I_M}{U_g I_{sc}} , \quad (17)$$

always being smaller than the unit. As this factor closer the unit is, the cell behavior is better. That means the cell voltage decreases the more slowly as the fill factor greater is, when the current grows.

e) The *cell efficiency* is generally defined as the ratio of the electric delivered power to the incident radiation power. The specific incident power on the cell surface may be written

$$P_i = \Phi \epsilon , \quad (18)$$

where is the photon flux

$$\Phi = nc \text{ (ph/m}^2\text{s)}, \quad (19)$$

n is the photons density (ph/m³), c is the light velocity and ε is the mean photon energy.

For the operating point M , the cell efficiency equation becomes:

$$\eta_M = \frac{I_L + I_0 q U_M^2}{nc\varepsilon(kT + qU_M)} \quad (20)$$

The cell efficiency depends on the width of the power gap E_g of the semiconductor. Because the number of photons having an energy greater than eE_g decreases when E_g grows, the maximum current intensity decreases too. On the other hand, the voltage U increases when E_g increases, because the no load voltage grows and the inverse current I_0 decreases. Owing these opposite dependences, the efficiency of the solar cell has a maximum for a given spectrum of the incident radiation.

In the case of the solar radiation, the maximum efficiency of the photoelectric conversion can be obtained if the power gap width is $1,1 < E_g < 1,9$ eV. This condition is fulfilled by some semiconductor materials, Table 2

Table 2 – Power gap with of semiconductor materials

Material	Si	InP	GaAs	CdTe	CdSe	GaP
E_g (eV)	1.11	1.29	1.39	1.45	1.74	2.24

While the cell temperature grows, the maximum efficiency value shifts to higher value of E_g , although this maximum decreases.

The rated values of solar cell parameters are done for the standard radiation, having a power density of 1000 W/m².

Energy losses of the solar cell

A photoelectric cell converts only a part of solar radiation into electricity, because more power losses appear. Some of these losses produce while the radiation interacts with the cell (fig. 9) by reflexion on the cell surface, by crossing the cell without absorption and by interacting with atom core or other than the valence electrons.

After the free loads are created, some of them recombine if appear too far from the junction to be directed by the inner electric field. Also, another loss appears because the inner impedance of the cell.

a) *Reflexion at the cell surface.*

The reflexion coefficient R_λ depends on the wave-length of the radiation, the surface material and the refraction coefficient of the semiconductor. For semiconductor materials having a power gap of 1.1 – 1.5 eV, the reflexion coefficient is

0.3 - 0.4 in the visible domain of solar radiation. To reduce the reflexion losses, an antireflexion layer covers the upper surface of the cell.

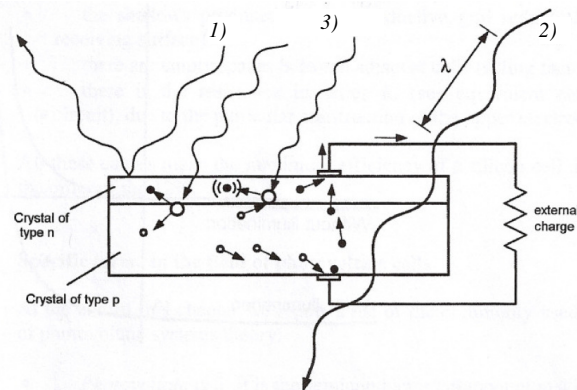

Fig. 9 - Different possibilities of interaction of the photons with a solar cell with junction P-N:

- 1) photon reflected by the external surface of the cell
- 2) photon crossing the cell without power exchanges
- 3) photon absorbed near the barrier of potential

b) *Partial absorption of the radiation.*

The absorption share of the applied radiation depends on the semiconductor material thickness and its absorption coefficient. The part of radiation crossing the cell without absorption decreases after an exponent law, while the cell thickness grows. Consequently, this loss would be reduced if the cell thickness grows. Such solution has only limited application because induce other losses growth.

c) *Free loads generation*

Some of the absorbed photons transmit their energy to the atoms core or to electrons on inner orbits, having as result only the atoms excitation and cell heating. The share of photons number that creates free load pairs is evaluated by the *quantum efficiency*: the ratio between the number of free load pairs created and the number of absorbed photons.

d) *Recombination*

If a photon is absorbed far from the junction, in a region where the inner field intensity is weaker, the speed of the free loads is too slow and the recombining becomes very likely. As consequence the photon power is again emitted but induces only the cell heating. To reduce this loss the cell thickness must be as smaller as possible. Because the losses by partial absorption of radiation, a compromise is compulsory regarding the cell thickness.

e) *Voltage loss*

Whatever semiconductor material has a defined resistivity and the cell has inner impedance like any electric source. The cell voltage results as the difference between the photoelectric voltage and the inner voltage drop caused by the circulation of the generated current through the cell. To reduce this loss, the

cell thickness must be small and the contact resistance as little as possible, too.

Structure of a actual solar cell

Most of the photovoltaic systems present on the market nowadays are built with crystalline silicon, material that can appear in two forms:

- monocrystalline
- multicrystalline or polycrystalline.

Besides these forms, another type of silicon is utilized more recently: amorphous silicon allied with hydrogen. Although its parameters are weaker than for crystalline silicon, it has the advantage of a much smaller cost.

This silicon used for solar cells can be of less purity than used for electronic semiconductor devices without affecting conversion efficiency. This quality of silicon is defined as "of sun degree" and is cheaper than that used for electronic semiconductor devices.

The photovoltaic cell is produced according to different operating steps.

The wastes of silicon or the silicon extracted from quartz are melted in an oven and then made crystallize in lingots. The melted silicon is doped to turn in semiconductor type P. After the lingot is cut into into 300 μm thick slices, follows the second doping to create a layer of type N at one of the slice surfaces.

To collect the free charges generated in the cell, electrical contacts must be added. Such contacts are set over the front and rear part of the silicon slice. To reduce the electrical resistors it would advisable to widen the contact area the more possible. The front contact must be so thin to become transparent for the solar radiation, while the rear contact can be thicker and so, of smaller resistance.

On the front surface, the cell is coated with a reflection prevention layer, usually TiO_2 . This treatment gives the cells the classical blue color for multicrystalline silicon or black color for monocrystalline silicon.

The more usual configuration of a solar cell is reported in fig. 10.

Electrical connection of the solar cells

A single cell has the output voltage of some 0,3 V while the delivered current intensity depends on the cell surface. To obtain a higher voltage the cells are connected in series building modules, panels and solar fields (fig.11).

Considering the electrical operation of the set of cells and remembering that the cells are semiconductor diodes, it can be noted that, whenever a cell should be obscured, the last would cease to behave as a generator, operating instead as inversely polarized diode; this would mean the block of the generated

current, canceling, in this way the power produced by the whole chain, i.e. by the module of series connected cells.

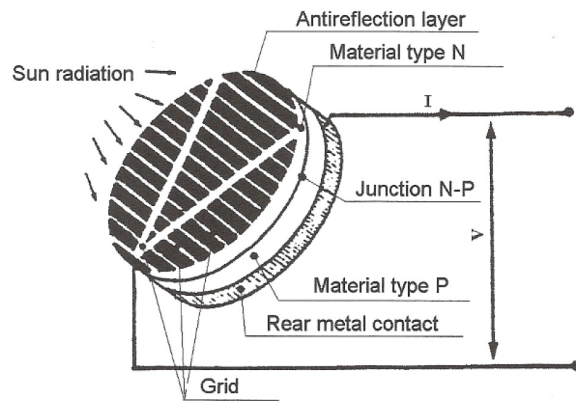

Fig. 10 — Diagram of the essential components of a solar cell

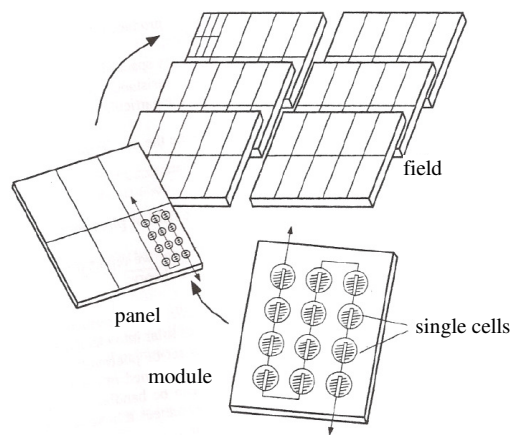

Fig.11-Inter-connected solar cells

In the case when one of the cells should be only partially obscured, the current across the module would be equal to the one such cell would produce if taken singularly. It is important, so, to make the photovoltaic modules—during their operation—to be obscured the less possible, even only partially, because each single module behaves as all the cells composing it should receive a quantity of solar radiation equal to the one less exposed cell receives; that would mean a reduction of the produced power more than proportional in respect the percentage of obscured surface.

It is important to see that in a set consisting in more cells (more modules connected in series) one is darkened and, in the meantime, the electrodes are kept in short-circuit or at very low voltage, the hot-spot phenomenon can occur. The darkened cell, in this case, is inversely polarized with a voltage equal or very near the no load voltage of the whole series composed of the remaining cells and exposed to the danger to enter reverse conduction. In this case the cell would find in the position to be obliged to dissipate the power generated by the remaining

cells of the module, causing a localized increase of temperature (hot-spot) that can take, even with modest solar radiation values, to the destruction of the cell by overheating. To solve these problems, the modules have mounted, in the terminal board, some diodes called by-pass, just on the purpose to short-circuit, and so, to insulate the single module in the case of malfunction.

The photovoltaic module consists in a set of cells connected in series. If the obtained voltage is not high enough, some modules are connected in series, too, building a string. To create the field, or photovoltaic generator, the strings, in turn, may be connected in parallel. The number of strings connected in parallel is related to the required current for the unit to be powered by the photovoltaic generator. (fig. 12). In fig.12, besides the by-pass diodes connected in parallel to each module, there are other diodes, connected in series with each string, called block-diodes; their function is to prevent the current flow inversion during the night.

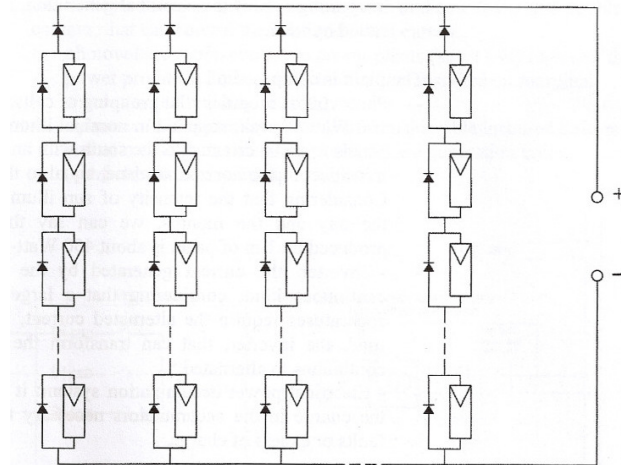

Fig. 12 Connection diagram of photovoltaic strings in parallel

Stand alone (off-grid) installation

An autonomous system is that in which the electrical power produced in excess in respect to the electrical charge, is accumulated inside batteries, in order to be used in moments of low insolation or at dark. This kind of system can be well applied to service, insulated users or mini-insulated lines.

Service: small power charges with service insulated from the grid such as pumping of small water quantities for sanitary use, power supply of telephone and radio repeaters, battery charger for boats, campers etc.

Insulated users: domestic with d.c. power distribution, or, for higher power needs, in alternating current as mountain huts, holiday houses etc.

Mini-insulated lines: photovoltaic plants of some tens of kW, distribution in alternating current often three-phase and with back-up of a diesel-electric set, dedicated to the

electrification of villages or communities far from the public grid.

An autonomous plant is composed of:

- Photovoltaic panels from 20 to 100 W_p , directed to the south with an inclination in respect to the horizontal plane, equal to the latitude of the place.
- Inverter: considering that a large part of the electrical apparatus requires alternating current, an inverter is used to convert the electrical power from continuous to alternating.
- Charge controller: it is a control system for the charge in batteries necessary to prevent damages for faults or excess of charge.
- Accumulators, e.g. Pb-acide batteries.

System connected to the public grid

In the grid-connected systems, the produced power is converted into electrical alternating current, and in the case this should not be used, it is delivered to public grid and counted with a double counter, that can control the inlet and outlet current. Such a system contains: photovoltaic field, local d.c. users, inverter, local a.c. users, grid breaker, counter.

Block diagrams of both systems are represented in the next figure.

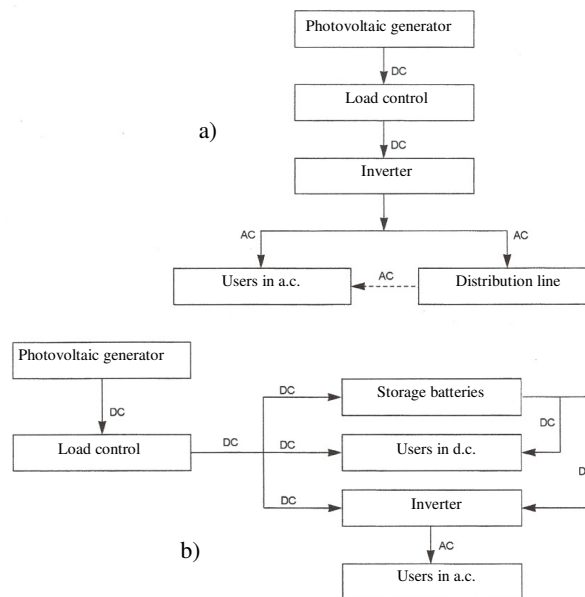

Fig.13 Block diagram of an insulated photovoltaic system b) and connected to the grid a)

Solar Photovoltaic Systems (PV)

In the early days of solar cells in the 1960s and 1970s, more energy was required to produce a cell than it could ever deliver during its lifetime. Since then, dramatic improvements have taken place in their efficiency and manufacturing methods. The energy payback period has been reduced to about 2-4 years, depending on the location of use, while panel lifetime has increased to over 25 years. The energy payback period of multi-junction thin-film concentrating PV is projected to be less than one year. As mentioned above, the cost of photovoltaic panels has come down. The current retail cost of solar panels results in system costs of US\$ 4-5/W which is cost effective for many Building Integrated applications. For MW-scale PV systems, however, the system costs have come down to US\$ 3/W which moves the technology closer to cost effectiveness for on-grid applications considering their long lifetimes (over 25 years), no fuel costs and low maintenance costs. Perhaps however, these dollar costs do not adequately portray the true environmental value of solar PV systems.

Even at an energy payback period of 3 years and a lifetime of 25 years, the return on energy investment is more than 8:1 and return on CO₂ avoidance is more than 6:1.

The limits imposed on the efficiency of solar cells due to band gap can be partially overcome by using multiple layers of solar cells stacked on top of each other, each layer with a band gap higher than the layer below it. The efficiency would increase with the number of layers. However, for this concept to work the thickness of each layer must be extremely small; this has been achieved by the development of Thin-Film PV technologies. Some of the materials being developed for thin-film solar cells include cadmium telluride (CdTe), copper indium diselenide (CIS), copper indium gallium diselenide (CIGS), gallium arsenide (GaAs) and indium phosphide (InP). Of these, CdTe and CIS are receiving the most commercial attention at this time. Multi-junction thin-film solar cells give even higher efficiencies when exposed to concentrated sunlight. Therefore, a great deal of commercial attention is being focused on Concentrating Photovoltaics or CPV.

Under concentrated sunlight, multi-junction (GaInP/GaAs/Ge [germanium]) solar cells have demonstrated efficiencies twice (39.3%) that of most silicon cells. This means that, in sunny areas, a multi-junction concentrator system can generate almost twice much electricity as a silicon panel with the same cell area. The concentrating optics focuses the light onto a small area of cells, reducing the area of the solar cells by a factor of, typically, 500-1000 times. The reduced cell area overcomes the increased cell cost. The cell cost is diminished in importance and is replaced by the cost of optics.

If the cost of the optics is comparable to the cost of the glass and support structure needed for silicon flat-plate modules, then the cost per unit area can remain fixed while the

electricity production is essentially doubled. Thus, in high direct insolation locations, multi-junction concentrator technology has the potential to reduce the cost of solar electricity by about a factor of two. The efficiency is a moving target; today's triple-junction cell efficiency is nearly 40%. Thus it may be reasonably extrapolated that multi-junction cells may reach 50% efficiency in the future.

The biggest advantage of solar PV systems is that they can provide from a few watts to hundreds of megawatts. Development of flexible thin-film PV panels (Fig. 10.11) makes them ideal for integration in building design. In this way, they can utilize the solar exposure provided by the buildings and therefore not use any extra land.